

HGO

series



UL O.S&Y Gate Valve – Grooved Ends

- Size: 2"(DN50) to 12"(DN300)
- Working Pressure: 200 PSI
- Test Pressure: 400 PSI
- Working Temp.: 0°C to 80°C (32°F to 176°F)
- Valve Standard: UL262,ULC/ORD C262-92
- Connection Standard: ANSI/AWWA C606
- Face to Face Standard: ASME B16.10
- Test Standard: UL262,ULC/ORD C262-92



HGO-200GG

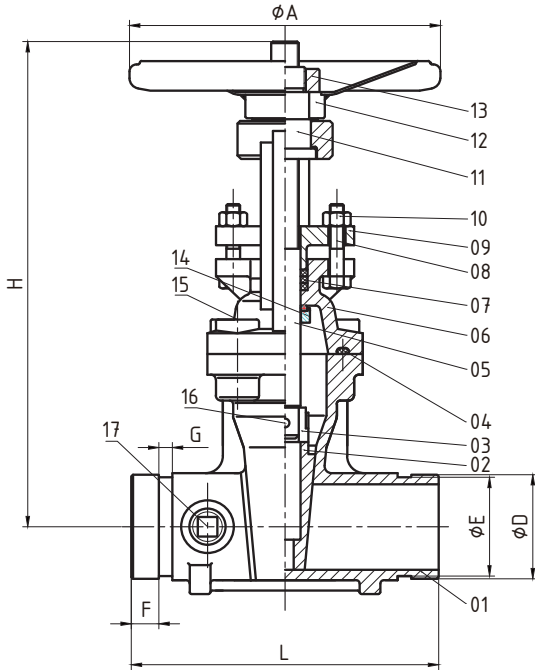

ITEM	PARTS	MATERIAL
1	BODY	DI ASTM A536 65-45-12
2	DISC	DI+EPDM ASTM A536 65-45-12 + EPDM
3	CONNECTING PART	C95400 ASTM B148
4	SEALING PAD	EPDM ASTM D2000 EPDM
5	STEM	S. S. 304 ASTM A276
6	CAP	DI ASTM A536 65-45-12
7	SEALING KITS	PTFE ASTM D4745
8	BOLT	STEEL ASTM A307 B
9	PLATEN	DI ASTM A536 65-45-12
10	NUT	STEEL
11	ROTATING NUT	C95400 ASTM B148
12	HANDWHEEL	STEEL ANSI 1045
13	LOCK NUT	STEEL ANSI 1045
14	FLAT KEY	S. S. 416 ASTM A276
15	COUNTERSUNK HEAD BOLT	STEEL
16	CYLINDER PIN	STEEL
17	PLUG	CAST BRONZE

SIZES		DIMENSIONS (MM)							
Inch	mm	L	H	φD	φA	φD	φE	F	G
2"	DN 50	178	313	152	180	60.3	57.2	15.9	7.9
2-1/2"	DN 65	190	340	178	200	76.1	72.3	15.9	7.9
3"	DN 80	203	387	191	220	88.9	84.9	15.9	7.9
4"	DN 100	229	440	229	250	114.3	110.1	15.9	9.5
5"	DN 125	254	546	254	280	141.3	137	15.9	9.5
6"	DN 150	267	607	279	300	168.3	163.9	15.9	9.5
8"	DN 200	292	786	343	350	219.1	214.4	19	11.1
10"	DN 250	330	946	406	406	273	268.3	19	12.7
12"	DN 300	356	1110	483	406	323.9	318.3	19	12.7